

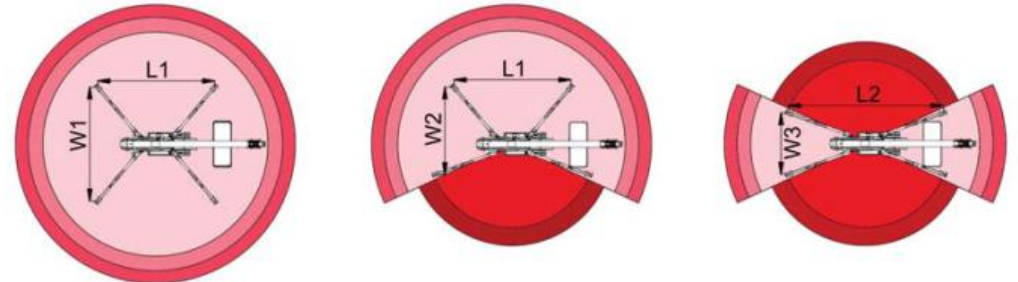

43 m ↑
18 m →
330 Kg 🧑🧑🧑

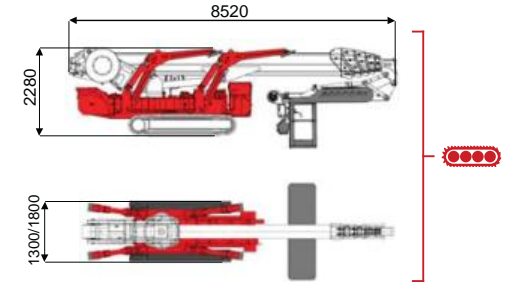

15000 mm	17000 mm	18000 mm	11500 mm	13500 mm	L1	L2	W1	W2	W3
330 kg	230 kg	120 kg	330 kg	120/230 kg	5760 mm	6870 mm	5330 mm	4510 mm	3690 mm

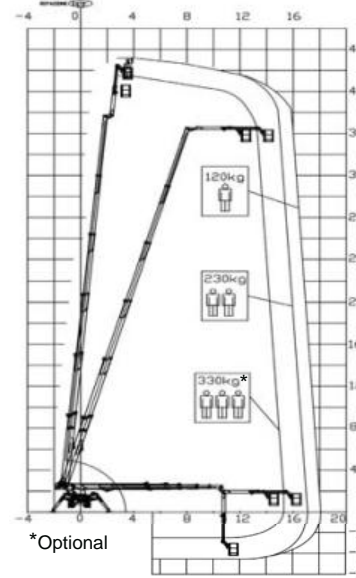

XTJ 43/C-R 43 m 18 m 330 kg 175° 660° 240x70 cm 90°+80° 3,69-5,33 m 25% 40% 2,25 km/h 10900 kg 75 kN 4,06 kN/m² 7,12 kN/m² 1350/1800 mm 8520 mm 2280 mm

Battery type	Battery charge	Add. Weight	Autonomy	Charging time	Electropump	
ECO DC+AC	48V 270 A/h 5h	230V-48V 45A	400 kg	6-7 h endless	7h	48V 9 kW

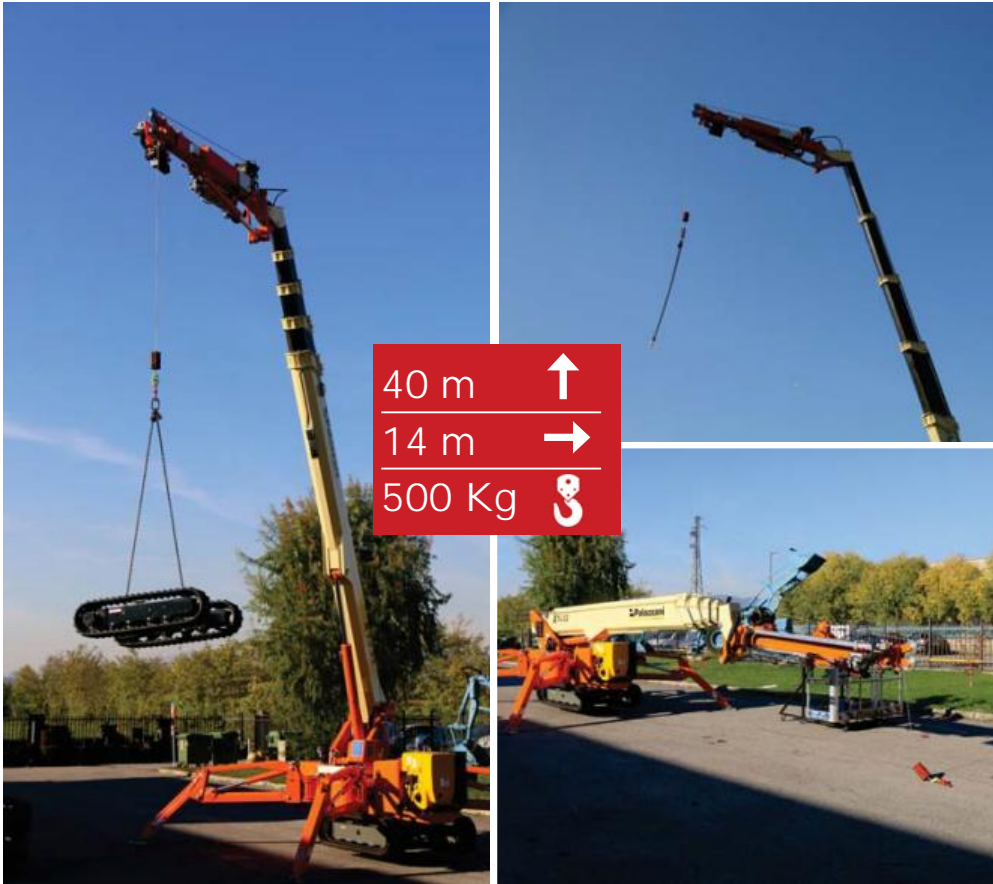

40 m ↑
14 m →
500 Kg ⚙️

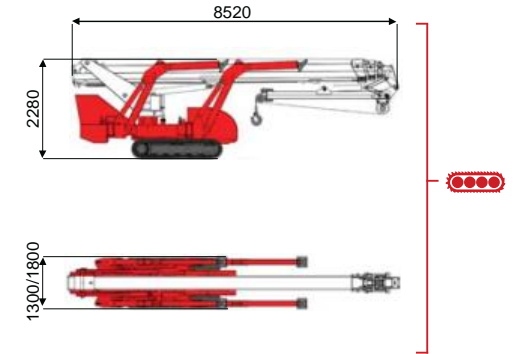
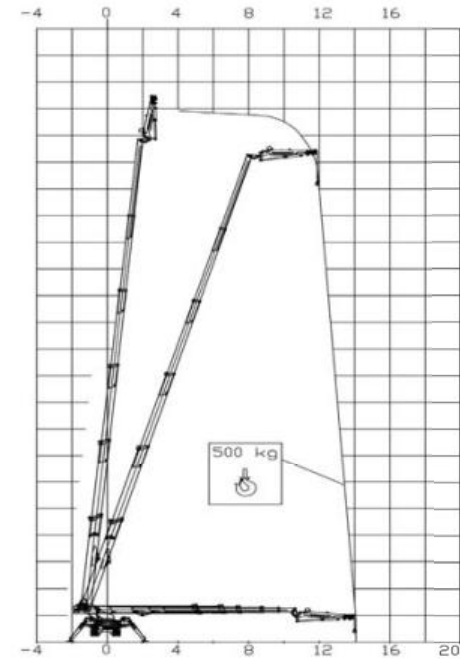

BI-ENERGY
Diesel+AC



XTJ 43/C-R



40 m

14 m

500 kg

660°

5,33 m

25%

40%

2,25 km/h

10900 kg

75 kN

4,06 kN/m²

7,12 kN/m²

1350/1800 mm

8520 mm

2280 mm



Battery type



Battery charge



Add. Weight



Autonomy



Charging time

Electropump

ECO

DC+AC



48V 270 A/h 5h

230V-48V 45A

400 kg

6-7 h endless

7h

48V 9kW

Palazzani
INDUSTRIE

Palazzani Industrie S.p.A.
Via del Pavione, 4
25050 - Paderno F.C. (BS) - Italy
Tel. (+39) 0306857073 Fax (+39) 030657079
platforms@palazzani.it
www.palazzani.it

COMPANY WITH
QUALITY SYSTEM
CERTIFIED BY DNV GL
= ISO 9001 =