

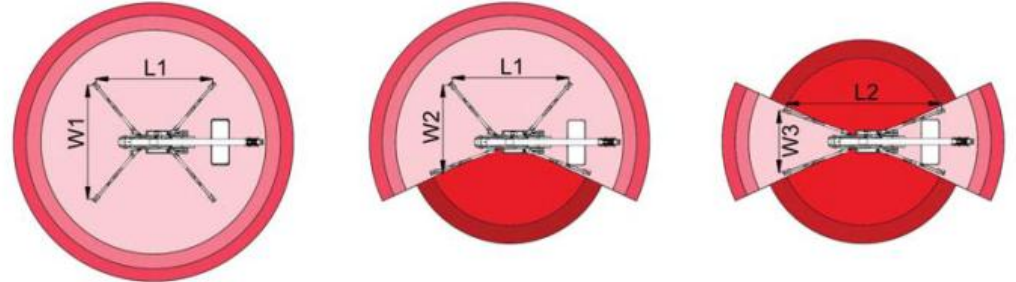

52 m ↑
19,5 m →
400 Kg 🧑🧑🧑🧑

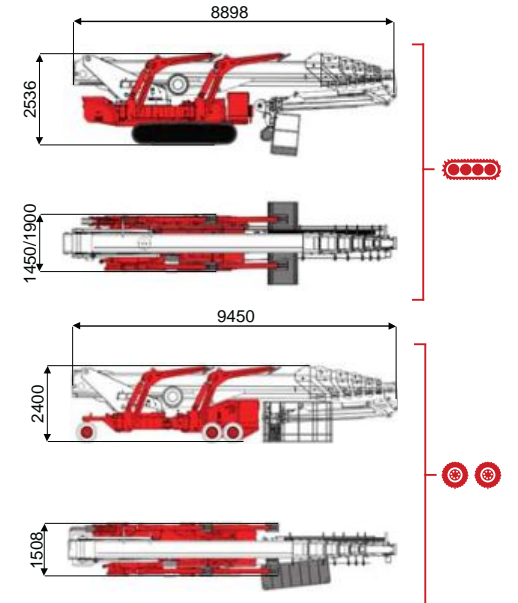
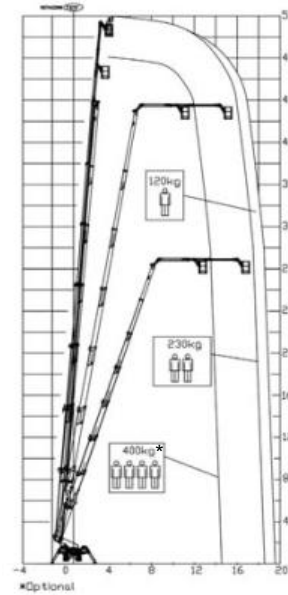

14000 mm	18000 mm	19000 mm	12000 mm	16000 mm	L1	L2	W1	W2	W3
400 kg	230 kg	120 kg	400 kg	120/230 kg	6250 mm	6946 mm	5000 mm	4500 mm	4000 mm

BI-ENERGY
Diesel+AC



XTJ 52/C	🔋	52 m	19,5 m	400 kg	170°	660°	240x70 cm	90°+80°	4-5 m	20%	40%	1,5 km/h	14000 kg	95 kN	4,19 kN/m²	6,55 kN/m²	1450/1900 mm	8898 mm	2536 mm
XTJ 52/R	🔋🔌	52 m	19,5 m	400 kg	170°	660°	240x70 cm	90°+80°	4-5 m	20%	25%	1,4 km/h	13000 kg	95 kN	3,90 kN/m²	6,09 kN/m²	1508 mm	9450 mm	2400 mm



Battery type



Battery charge



Add. Weight



Autonomy



Charging time

Electropump

ECO	DC+AC	🔋🔌	48V 270 A/h 5h	230V-48V 45A	400 kg	6-7 h endless	7h	48V 9 kW
-----	-------	----	----------------	--------------	--------	---------------	----	----------



45,5 m ↑
12 m →
500 Kg ⚙️

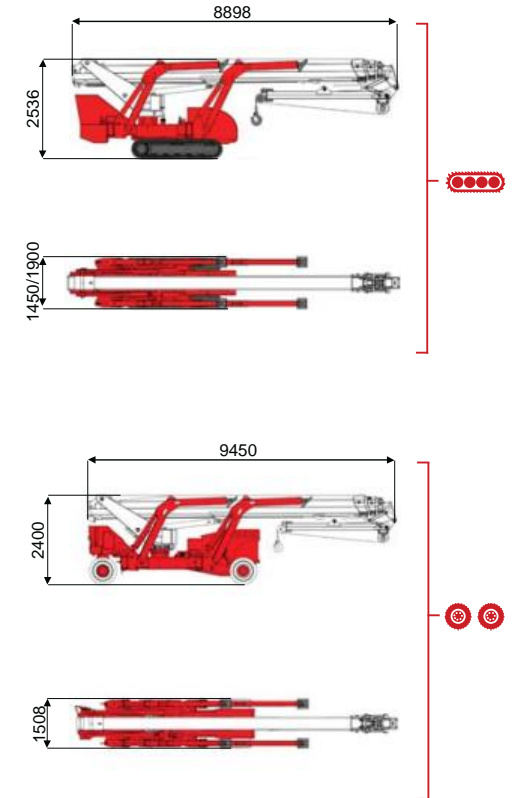
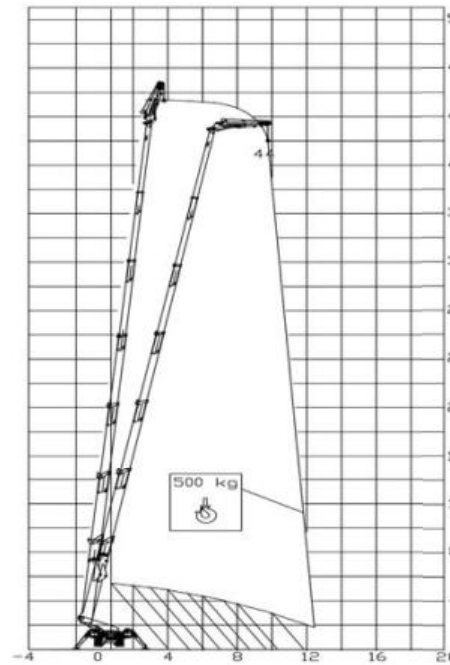

BI-ENERGY
Diesel+AC



XTJ 52/C		45,5 m	12 m	500 kg	660°	5 m	20%	40%	1,5 km/h	14000 kg	95 kN	4,19 kN/m ²	6,55 kN/m ²	1450/1900 mm	8898 mm	2536 mm
XTJ 52/R		45,5 m	12 m	500 kg	660°	5 m	20%	25%	1,4 km/h	13000 kg	95 kN	3,90 kN/m ²	6,09 kN/m ²	1508 mm	9450 mm	2400 mm



Battery type



Battery charge



Add. Weight



Autonomy



Charging time

Electropump

ECO	DC+AC		48V 270 A/h 5h	230V-48V 45A	400 kg	6-7 h endless	7h	48V 9kW
-----	-------	--	----------------	--------------	--------	---------------	----	---------

Palazzani
INDUSTRIE

Palazzani Industrie S.p.A.
Via del Pavione, 4
25050 - Paderno F.C. (BS) - Italy
Tel. (+39) 0306857073 Fax (+39) 030657079
platforms@palazzani.it
www.palazzani.it

COMPANY WITH
QUALITY SYSTEM
CERTIFIED BY DNV GL
= ISO 9001 =